

# Thermomix® Sensor

## Welcome Booklet



thermomix  
VORWERK

# Contents

- 4** What is Thermomix® Sensor?
- 6** First steps
- 8** How to set up Thermomix® Sensor
- 10** How to use Thermomix® Sensor
  
- 14** Recipes
  - Perfect inside and out
- 18** Meat
- 19** Beef
- 20** Pork
- 21** Lamb
- 22** Poultry
- 24** Fish
- 26** Bread
- 30** Cake
  
- 34** FAQs
- 41** Food safety note



# What is Thermomix® Sensor?

Thermomix® Sensor is a food thermometer, but it's also so much more. With Thermomix® Sensor, we are extending for the very first time the Thermomix® Guided Cooking experience to your oven, stove top and grill. It's all about knowing the precise core temperature to have the perfect texture for your cakes, breads, meats and fish.





Holder

Charger

Probe

# First steps

Getting started with Thermomix® Sensor is quick and easy. Just install it once and use it for your daily cooking. As simple as: "Insert Thermomix® Sensor".

**1.** Unbox your Thermomix® Sensor. Open the battery compartment at the back of Thermomix® Sensor and remove the protective film to release the battery. By doing so you will initiate the charging of the probe's battery.

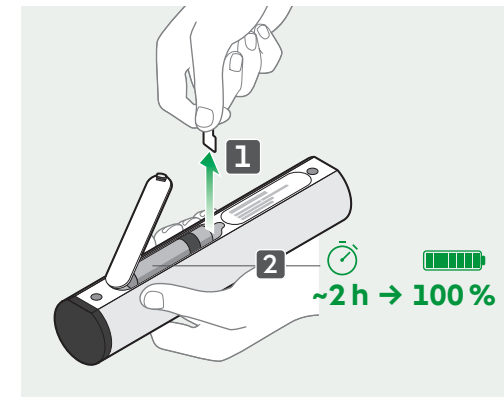

**2.** Read the Quick Start card and get familiar with the safety instructions in the instruction manual.

**3.** After 2 hours maximum initial charging time, your Thermomix® Sensor is fully charged and ready to use.

Once fully charged, the battery will last 24 h.

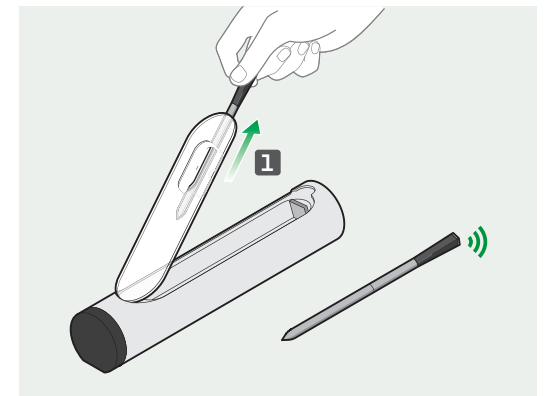

**4.** Open the charger and extract the probe. When you remove the probe from the charger, the LED flashes green indicating the charger is connected to the probe.

**5.** Before using it for the first time, clean the probe with water and dish soap to remove any production residues.

Quick,  
safe and easy  
to use.

# How to set up Thermomix® Sensor

## 1 Switching on and off

When you take the probe out of the charger, it will automatically be switched on and be ready to use. To switch the probe off, put it back into the charger and close it.

## 2 Connecting your Thermomix® Sensor to Thermomix® TM6®

On your appliance display, proceed as follows:

- Remove probe from charger.
- Select "Menu".
- Select "Settings".
- Activate the Bluetooth® if not already on.
- Select "Connected devices" (Please note that only 1 Sensor at a time can be connected to your Thermomix® device).
- Select "Thermomix® Sensor"/"Add device".
- Click the new Thermomix® Sensor to start pairing.
- Thermomix® Sensor is now connected.

You can access Thermomix® Sensor mode via the Modes and Tools screen on Thermomix® TM6®.

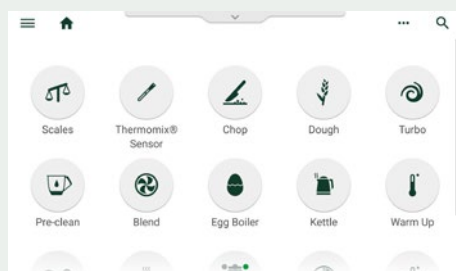

## Cooking Center

The Cooking Center allows you to check, from any screen on your Thermomix® TM6® display and at any time during the cooking session, the current cooking status of your recipe step.

Whether in Guided Cooking mode or cooking manually, click on the Cooking Center menu on top of your screen:



And access:

- Your recipe status: remaining cooking time, current and target temperature and speed.
- Timer
- Thermomix® Sensor

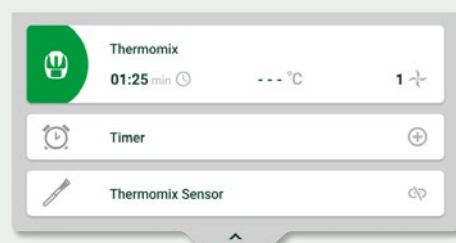

## 3 Connecting your Thermomix® Sensor to Cooking Center Mobile app

- Scan the QR Code here below to install the Cooking Center Mobile app from the App Store or Google's Play Store.



- Open the app. To be able to use Thermomix® Sensor with the Cooking Center Mobile app, tap the "+" button in the right bottom corner of the app then select "Thermomix® Sensor". You are asked to provide permission to use Bluetooth® and receive notifications (Android might ask to use Local Services). In order to get Thermomix® Sensor to work, make sure you provide your consent.

Once connected to Bluetooth®, the app will find Thermomix® Sensor and pair it to the app.

After pairing Thermomix® Sensor to the app, a new card with Thermomix® Sensor will appear on the home screen. Tap the card to start.

To start cooking or baking with Thermomix® Sensor, simply tap "set temperature" and our wizard will guide you through the best options for the food you want to prepare. If you know the core temperature you need, you can also set a temperature manually.

# How to use Thermomix® Sensor

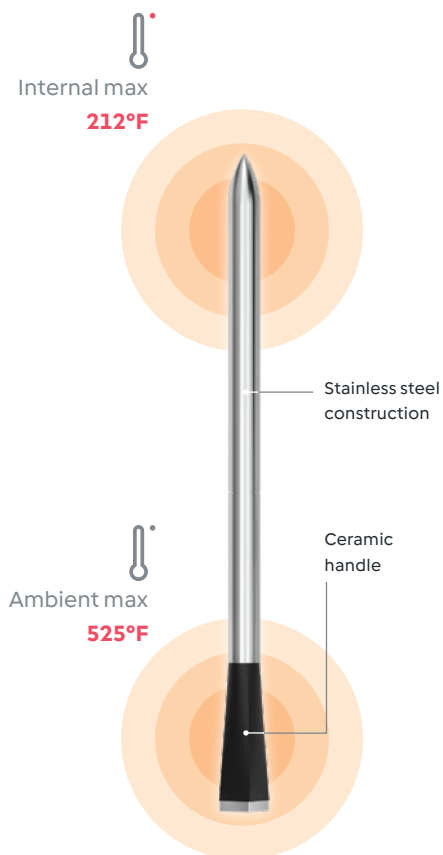

## 1 Positioning the probe and charger

During the cooking process, the probe continually transmits data to Thermomix® TM6® and the app. The charger acts as a repeater and amplifies the signal. You must therefore ensure that the charger is always near the probe: for example, when

baking, place the charger close to the oven. The charger can be placed on the outside of the oven using the magnets which are on the back of the charger case.

Thermomix® TM6® can be a little further away from the probe and its charger (between 3–164 ft depending on the environment).

## 2 Inserting the probe into the food

Thermomix® Sensor is a Bluetooth® thermometer with two sensors. The internal temperature sensor is located in the first third of the tip. It measures the internal temperature of the food and therefore needs to be positioned as close as possible to the core of the food. The second sensor is located inside the black ceramic end and measures the ambient temperature.

The reference notch (see illustration on page 11) also needs to be inserted into the food to ensure correct temperature readings and accurate time calculations. For doughs and batters that will continue rising while baking, the reference notch does not necessarily need to be fully inserted but placed close to the batter surface.



To use Thermomix® Sensor, fish or meat fillets should not be less than ¾ inch thick.

Insert the probe (tip and reference notch) into the center of the thickest part of the food.

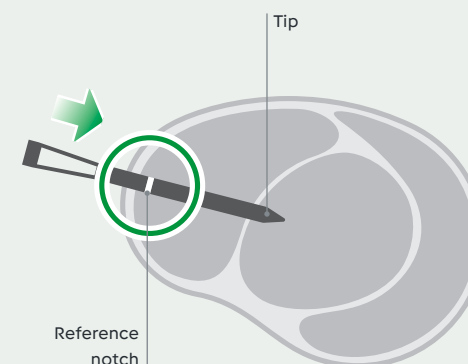

### Using the holder

When baking certain doughs (e.g. cake doughs with a soft or fairly liquid consistency which cannot hold the probe in position), you need to use the holder to maintain the probe in the right position in the food and prevent it from sinking into the dough.

To use the holder, you can choose between two different insertion angles, A and B (see illustration below), depending on the size of the baking pan and the quantity of batter.

You may refer to the videos available on TM6® Guided Cooking recipes and on the app.

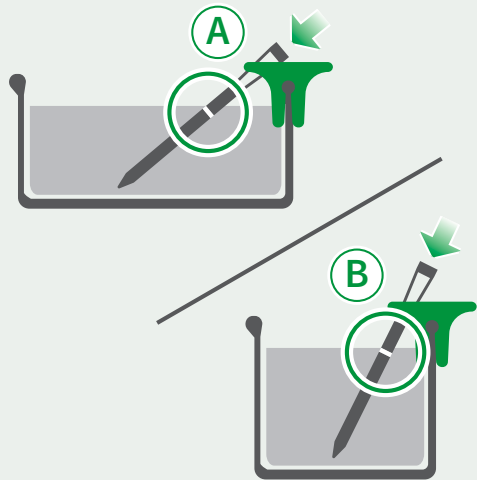

The holder can be used up to a temperature of 425°F.

Place the holder on the edge of the baking pan as shown below, slide the probe through the holder then into the food.

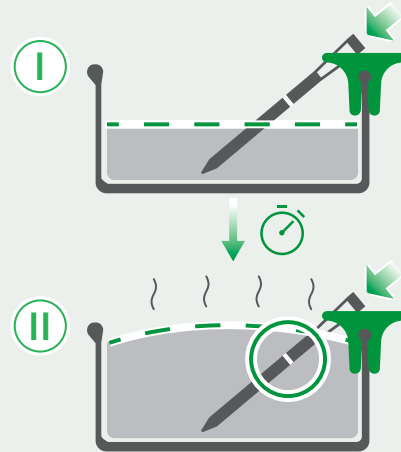

For dough that rises, the insertion depth of the probe may vary.

- I. Dough level before baking: the probe is inserted at least halfway between tip and notch. The reference notch may be visible.
- II. Dough rises during baking and covers the notch.

Make sure that the tip of the probe never touches the baking pan.

### 3 Cooking with the probe

During the cooking process, Thermomix® Sensor is permanently connected to your Thermomix® TM6® and/or to the Cooking Center app (max. 2 connected devices). Make sure you have allowed notifications in the app settings, then you will receive information on the temperature and remaining cooking time on the display. You will be notified when the meat or fish need to be removed from the heat to let it rest until the core temperature is reached. After the resting time, your dish will be ready to serve.

### Cooking freestyle

The black ceramic end of the probe should not be exposed to excessive heat. If you use it with very high temperatures, for example with a barbecue or a sizzle plate, sear the food first over high heat then slide it over lower heat (less than 525°F) before inserting the sensor. Should the probe get too hot, you will get a notification on the Cooking Center (app or device).

When cooking in a pan, or on the grill, remember to flip the meat or fish once the surface underneath is browned.

### 4 Cleaning

- Allow the probe to cool down before cleaning.
- Clean the probe and the holder with water and dish soap after every use. Do not use cleaning products that contain alcohol, ammonia, benzene or abrasives as these could damage the device.
- Do not immerse the probe in water for long periods of time.
- Make sure that probe and holder are completely dry before putting it back in the charger.
- After continued usage, the probe may become tarnished. This is normal and will not affect the performance of the probe.

### Tips

- For best results with charcoal barbecues, wait for the flames to die down. The easiest technique to control the temperature across the grill is then to put all the coals to one side, so you have a very hot side and one with no direct heat.
- If you are using a gas barbecue or a pan on a stove, ensure you do not exceed the maximum temperature of 525°F.
- Don't stab or cut your meat while it is cooking to avoid the juices draining and leaving you with dry food. Do not forget to turn the meat or the fish once or twice during the cooking process.
- Never leave the grill unattended while children or pets are around.



## Recipes

Perfect inside  
and out



Turn a guess into success with  
Thermomix® Sensor.



## Thermomix® Sensor is *the* Accessory that completes your kitchen

*Thermomix® Sensor gives your daily meals or festive gatherings greater confidence with nothing less than perfect results.*

*What if you could feel your food from the inside...and be able to check if a cake is properly baked or fish is perfectly cooked? How many times have you stopped yourself from testing new recipes in fear that you won't get it right?*

*Thermomix® Sensor will become your best ally because each food has its own cooking point and only the precision of Thermomix® Sensor will help you reach perfection.*



### Why use Thermomix® Sensor?

- Enjoy the Guided Cooking experience for the very first time outside the mixing bowl for your oven, stovetop and grill
- Ensures greater food safety by guaranteeing the right core temperature
- Monitor your cooking status in the Cooking Center of your Thermomix® TM6® and get notifications also on your smartphone
- Obtain chef's quality cooking results
- High precision on monitoring the core and ambient temperatures
- Simple to use: take the probe out of the charger and follow the instructions on Thermomix® TM6® and/or the app
- Reliable Bluetooth® system



Thermomix® Sensor probe may be used at a maximum ambient temperature of 525°F. The maximum core temperature that can be measured is 212°F.

### The magic trio: Thermomix® + Sensor + Cooking Center app.

Thermomix® Sensor is the perfect addition to your Thermomix®. The sequence is very simple:

1. Start cooking as usual with your Thermomix®.
2. Follow step-by-step instructions on your Thermomix® display or directly in the Cooking Center app and use Thermomix® Sensor as indicated.
3. Check the progress of your recipe via the Cooking Center menu on your Thermomix® or wait for the notification on your smartphone when your meat, fish or bread is ready.

### What can I cook with Thermomix® Sensor?

Use with breads, cakes, meat, poultry, and fish.

### What devices can it be used with?

Thermomix® Sensor works with the following kitchen appliances: oven, barbecue, and stove top cookware.



## Beef

### Beef Wellington made easy!

*One of the fundamental rules for tender beef is to cook it precisely to your desired doneness.*

*Getting a pinkish hue, inside a sirloin, without the meat being raw, is no easy task. Even less so if wrapped in puff pastry. We have good news for you!*

*Thermomix® Sensor will help you get it just right.*

Thermomix® Sensor provides you with the core temperature needed for each cut of beef to reach your preferred level of doneness, whether rare, medium rare, medium, medium well, well done or fall apart tender (e.g., pulled pork or brisket).



**For steak** – If possible, buy an evenly thick cut of meat.

Once you have selected the piece of beef you wish to prepare, and selected the cut in the list available within Thermomix® Sensor mode on TM6® or within the app, insert the probe ensuring the tip is fully inserted into the center of the thickest part of the cut and the reference notch is fully inserted in the meat.

- For steaks, insert probe horizontally from one side of the steak.
- For bone-in cuts, such as roasts, insert the probe diagonally from the top.
- For cuts with bones make sure the probe is not touching the bone.

Once the cooking point is selected and the probe correctly inserted, press START.

Thermomix® Sensor will show the estimated cooking time and the current core temperature. For meats, after a few minutes, the initial estimated cooking time will continually update as the core temperature increases. You will get a notification to remove the meat from the heat and let it rest until the core temperature is reached. After the resting time, the meat is ready to serve.

# Pork

The cooking points available for pork are medium rare, medium, medium well, well done and pulled, each of them being offered for relevant cuts only. Once you have selected the piece of pork you wish to prepare, and selected the cut in the list available, insert the probe ensuring the tip is fully inserted into the center of the thickest part of the cut and the reference notch is fully inserted in the meat.

- For steaks (e.g. chops) insert probe horizontally from one side of the steak.
- For bigger cuts, such as roasts, insert the probe diagonally from the top.
- For bone-in cuts make sure the probe is not touching the bone.

Once the cooking point is selected and the probe correctly inserted, press START.

Thermomix® Sensor will show the estimated cooking time and the current core temperature. For meats, after a few minutes, the initial estimated cooking time will continually update as the core temperature increases.

You will get a notification to remove the meat from the heat and let it rest until the core temperature is reached. After the resting time, the meat is ready to serve.



**When cooking ribs, ensure there is approx. ¾ inch of meat on the bones.**

**When cooking meat with bones, insert the probe parallel to the bone, not pointing towards it.**



# Lamb

The cooking points available for lamb are rare, medium rare, medium, medium well, well done and fall apart tender, each of them being offered for relevant cuts only.

Once you have selected the piece of lamb you wish to prepare, and selected the cut in the list available, insert the probe ensuring the tip is fully inserted into the center of the thickest part of the cut and the reference notch is fully inserted in the meat.

- For chops or flat cuts insert the probe horizontally from one side of the cut.
- For bigger cuts, such as roasts, insert the probe diagonally from the top.
- For bone-in cuts make sure the probe is not touching the bone.

Once the cooking point is selected and the probe correctly inserted, press START.

Thermomix® Sensor will show the estimated cooking time and the current core temperature. For meats, after a few minutes, the initial estimated cooking time will continually update as the core temperature increases.

You will get a notification to remove the meat from the heat and let it rest until the core temperature is reached. After the resting time, the meat is ready to serve.



# Poultry

## Perfect turkey

*Not too much, not too little. Just right.*

*Cooking the perfect turkey can, be challenging, to say the least: knowing when to take it out of the oven is not easy.*

*Like all foods, turkey has a perfection point! Time for marinating, as tradition prescribes. Time to cook evenly and time to be gloriously tasted.*

*While in the oven you may wonder... whether the temperature is right? Or whether the skin will be crackling the way you like it...? So you go back and forth to the kitchen to keep an eye on the turkey.*

*But that was before! Now you can make the best of your time while the turkey is roasting, and enjoy a cup of tea until you receive a message on your smartphone.*

*The turkey is ready. Not too much, not too little. Just right.*

The Poultry category covers a varied range of birds from chicken to goose.

The cooking points available will differ depending on the type of poultry you select.

For example, duck and goose breasts allow rare and medium rare cooking points while chicken and turkey do not for food safety reasons.

When cooking feathered game or wild poultry, refer to the duck category.

Once you have selected the type of poultry from the list available: chicken, turkey, duck, or goose, and selected the cut in the list available: whole birds, or specific cuts, with or without bones (breast, leg, or thigh), insert the probe ensuring the tip is fully inserted into the center of the thickest part of the cut and the reference notch is fully inserted in the meat.



- For whole birds insert the probe in the thickest part of the breast.
- For breasts insert the probe horizontally in the thickest part of the cut.
- For bone-in cuts and whole birds, make sure the probe is not touching the bones.

Once the cooking point is selected and the probe correctly inserted, press START.

Thermomix® Sensor will show the estimated cooking time and the current core temperature. For meats, after a few minutes, the initial estimated cooking time will continually update as the core temperature increases. You will get a notification to remove the meat from the heat and let it rest until the core temperature is reached. After the resting time, the meat is ready to serve.



**When cooking on a barbecue, ensure the probe's ceramic end is minimum 4 in. away from the heat source.**

# Fish



## Cook a whole fish

*with confidence*

*Fish is very delicate. Cooking with the Thermomix® Sensor will maintain the delicate texture and flakiness of your fish.*

*Grilled, steamed, boiled, fried or oven-roasted, fish is one of the foods for which the right level of doneness is essential. Think of your Thermomix® Sensor as your guide to perfectly cooked fish..*

The Fish category on the cooking center mobile app covers various types of fish. If the exact type you are looking for is not listed, select "other".

The cooking points available for fish are medium, medium well and well done.

Once you have selected the type of fish from the list, and selected the cut in the list available, insert the probe ensuring the tip is fully inserted into the center of the thickest part of the cut and the reference notch is fully inserted in the fish. Please note that "Other" refers to whole fish or bigger cuts. Best results for fish are obtained with large fillets or whole fish.

- For fillets insert probe horizontally in the thickest part.
- For whole fish insert the probe in the thickest part and avoid touching the spine and bones.

Once the cooking point is selected and the probe correctly inserted, press START.

Thermomix® Sensor will show the estimated cooking time and the current core temperature. For fish, after a few minutes, the initial estimated

cooking time will continually update as the core temperature increases.

Once the core temperature is reached, you will get a notification to remove the fish from the heat.

It will also tell you how long it should rest to ensure you serve it cooked just right.



### GOOD TO KNOW

The total recipe cooking time will depend on the weight and thickness of the meat or fish, the initial temperature of the food and your preferred degree of doneness.

# Bread



## Baking bread to perfection

*The best thing about making bread at home is you can bake it the way you want! Whether you prefer crunchy, soft or well baked, the Thermomix® Sensor allows you to bake your bread to your desired doneness.*

*Baking homemade bread gives you an unparalleled feeling of satisfaction. It is the experience of being able, with only two or three basic ingredients, to create a food which is central to almost all gastronomic cultures.*

*In addition to a good dough and the right leavening, baking is crucial.*

*Most of the time, the oven must be preheated to reach a higher temperature and create the much-desired crispy crust. It is important to reach the ideal baking point, and for this you no longer need to knock on the bottom of the hot bread to check for the desired hollow sound. Now, all you have to do is wait for the notification on your smartphone. Get ready to spread with butter!*

**Make sure that the tip of the probe never touches the baking pan.**



Firstly, it is important to check whether the recipe you wish to prepare belongs to the Bread group. If so, you need to identify to which bread type.

Bread doughs are basically a combination of flour, water, salt and yeast or sourdough. Some doughs might contain beer or baking powder as leavening agents. Doughs can be savory or sweet. In most cases doughs can be handled with hands.

- **Basic doughs** contain flour, water or other non-fatty liquid, salt and yeast or another fermenting agent. They may also contain herbs, spices, and seeds.
- Besides flour, water, salt and yeast, **rich doughs** also contain fat (butter, oil, lard), sugar or honey, eggs, cream, etc. A rich dough can contain part or all these ingredients (e.g. brioche, panettone, Spanish Kings' Cake).

Some cakes containing fresh fruit, vegetables, eggs, sugar but no yeast, might be called bread (e.g. Banana bread). They should be baked using Cake Mode (Basic and fresh fruit cakes option, instead of Bread Mode).

Once the dough is ready to be baked, choose whether it is a basic or a rich dough. Insert the probe into the dough ensuring the tip is in the center of the dough and the reference notch entirely or close (min. 1/3 inch) to the dough surface. The dough will cover it when rising. Make sure the tip of the probe does not touch the baking pan.

If the dough is not firm enough to hold the probe, a baking pan will be needed. In such case, use the holder to keep the probe in place.

Once the bread type is selected and the probe correctly inserted, press START.



Bake the bread until the core temperature shown in the Cooking Center reaches the target temperature. Thermomix® Sensor will show the estimated baking time and the current core temperature. The estimated baking time will adjust progressively as the core temperature increases.

Once the core temperature is reached, you will get a notification to remove the bread from the oven. If you prefer a darker crust, bake an additional 3–5 minutes after the notification to remove the bread from the heat.

Always let the bread cool down out of the oven before removing the probe, cutting and serving. If bread is cut/served while still very hot, the crumb will still be too moist and will not hold itself.

Thermomix® Sensor removes the guesswork from your baking, regardless of the type of oven you use, dough shape, or baking pan. It ensures the perfect core temperature even if the baking time varies from that of the recipe.

# Cake



## How to master cake delicacy?

*Find out how they feel inside*

Cake batters are normally thinner than bread doughs and require a baking pan. Most cake batters contain flour, eggs, sugar with a leavening agent whether baking powder, baking soda or whipped egg whites.

The cake types available in Thermomix® Sensor mode are the following:

- **Basic and Fresh Fruit Cakes:**

- Basic cakes contain little or no additional fat other than egg yolks (e.g. sponge cake)

- Fresh fruit cakes have a relevant amount of raw or cooked fruit or vegetables mixed in the batter (e.g. banana bread, carrot cake) plus additional ingredients such as butter

- **Rich cakes** are basic cakes with additional fat and/or ingredients such as chocolate, caramel and/or other creams or spreads (e.g. marble cake, yogurt cake, lemon cake, pound cakes)

- **Dried fruit cakes** are cakes containing a relevant amount of dried fruit plus additional ingredients such as spices and citrus peels (e.g. Christmas cake, Farmhouse fruit cake)

- **Other cakes:** cakes whose core consistency is moist, softer and creamier (e.g. lava cakes)

Thermomix® Sensor provides you with the right core temperature for the cake type you have selected.

Choose the type of cake and the option you need:

- Basic and fresh fruit cakes
- Rich cakes and pound cakes
- Dried fruit cakes
- Other cakes

Place the holder on the baking pan rim, position A or B facing inside the pan, according to the instructions of the recipe or to the depth of the batter:

- Use position A for standard rectangular (placed on the short side) or round cake pans
- Use position B when the holder is placed on the internal rim (Bundt pans or narrow and deep tube pans)

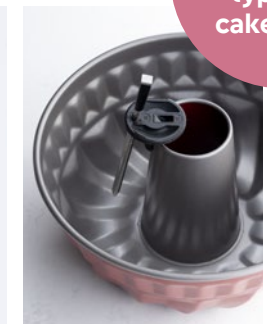

Suitable for most types of cake pans.





For best results, fill cake pans  $\frac{2}{3}$  high with batter or halfway for shallow pans.

Insert the probe, using position A or B (see p. 12), into the batter making sure the tip is inserted in the center of the dough. The reference notch might not be fully inserted but should be as close as possible to the dough surface (min.  $\frac{1}{8}$  inch) as the dough will cover it while rising during baking.

Once the cooking point is selected and the probe correctly inserted, press START.

Thermomix® Sensor will show the estimated baking time and the current core temperature. The estimated baking time will adjust progressively as the core temperature increases. Once the core temperature is reached, you will get a notification to remove the cake from the oven. Always let the baked items cool before removing the probe.

Best results are obtained with regular shape pans (circular and rectangular or any other shape providing the probe's internal sensor can reach the center of the batter), with regular straight edges and thin rims (no fluted edges or large rims).

For accurate temperature readings, it is essential that the holder is correctly placed in a stable manner and the probe properly inserted in the center of the food. This will not be possible if using pans with large or wide rims, small pans such as muffin pans or specialty and shaped pans.



**GOOD TO KNOW**

For baking, cooking time will depend on the type of batter, the size of your pan and whether you are using a convection or conventional oven.

Simply follow the instructions, given by Thermomix® Sensor, which provides precise control of your baking and ensures the perfect core temperature even if the baking time varies.



If your cake is browning too fast, cover it with parchment paper.

# FAQs

## How can I check my battery levels?

On Thermomix® TM6®:

- Open Settings
- Connected devices
- Thermomix® Sensor
- Thermomix® Sensor version and update

On your smartphone:

- Open the Cooking Center app
- Select Thermomix® Sensor card
- Press "Settings" on the top right corner of the screen to reach the device screen

## Do I have to replace the charger battery?

The charger battery can last up to a year if used an average of twice a week. You'll know when the battery needs replacing as you will get a warning on Thermomix® TM6® or your smartphone. To change the battery, remove the back cover, use the black plastic strip to easily remove the used battery, and replace with a new AAA battery.

## How long does the Thermomix® Sensor probe's battery charge last?

Once fully charged, probe's battery will last 24 h.

## What should I do if my Thermomix® Sensor probe stops connecting?

Clean the probe and tip thoroughly as residue can build up on the probe even if you are not able to see it.

The most effective way to get rid of any residue is scrubbing the probe well with a mixture of baking soda (bicarbonate of soda) and white vinegar using the rough side of a sponge, then giving it a quick wash ensuring it's completely dry before placing it back in the charger. You might also want to wipe the metal contact points on the charger with a dry cloth to remove any potential leftover residue. Afterwards, just let the probe charge for 2 hours.

Once your probe is connected again, make sure to get it sparkling clean after every usage. Most times, hot, soapy water and the rough side of a sponge will be enough. For discoloration, use a mixture of baking soda and vinegar and scrub with the rough side of a sponge.

It is essential to clean the probe after each use.



## Why does my Thermomix® Sensor keep disconnecting while in the middle of cooking?

Thermomix® Sensor charger has a built-in Bluetooth® repeater to amplify the probe signal, so you will need to keep it close to the probe during a cooking session to get proper range extension.

- If the LED on the charger flashes red, it indicates that the charger is trying to establish a connection with the probe, or that there is no connection. You need to place the charger closer to the oven (or barbecue).

If this does not help, carefully remove probe from the food, clean it, place it back in the charger for 5 seconds before inserting it back into the food.

- If the LED on the charger flashes green, the charger is on and is connected to the probe.
- A green blinking light on Thermomix® Sensor charger indicates that the charger is on and is connected to the probe.



### **Should I be worried that my Thermomix® Sensor probe keeps disconnecting?**

Thermomix® Sensor probe uses Bluetooth® to communicate to your device and to the app.

With Bluetooth® there are limitations on the range, especially if you are cooking with heavily insulated cooking appliances. You should be able to get a max. of 164 ft. from your probe in the open air, but certain smokers/grills and ovens (the thicker the material and the fewer gaps for the signal to escape) will cause range to decrease. If you find that your Thermomix® Sensor probe is disconnecting, don't worry, Thermomix® Sensor app has been built to handle all types of disconnections, which means, when you do reconnect, the cooking process will update, and carry on as normal.

Towards the end of the cooking time, we recommend keeping the connection active, so you don't miss any important notifications.

### **My Thermomix® Sensor disconnects as soon as I shut my oven door, is it faulty?**

Certain oven doors are more insulated than others, which can cause the Bluetooth® connection to drop. It could also be that the probe's

ceramic end is covered with food or is touching the pan. Using a metallic pot with a lid or covering the dish with foil rather than parchment paper can also cause the Bluetooth® connection to drop.

Always place the charger as close as possible to the oven door, ideally using the charger's magnetic contacts.

It may occur that the Bluetooth® connection drops. Should this happen, switch Bluetooth® off and on again. Having an additional device (such as a smartphone) can help to check if your probe is connected or not. If you find that you can reconnect to the probe easily when you open the oven door, it is most likely that your oven is too insulated to allow a stable Bluetooth® connection.

### **How do I store my Thermomix® Sensor probe correctly in the charger?**

Before placing the probe back into the charger, make sure it has been cleaned properly and all fat residue has been removed.

The probe should be completely dry before being threaded through the holes in the clear plastic cover and closing the charger.

### **How many smart devices can I connect at a time to Thermomix® Sensor?**

Thermomix® Sensor can only be connected to 2 devices at a time, whether 2 Thermomix® TM6®, 1 Thermomix® TM6® and a smartphone or 2 smartphones.

### **Why isn't the Thermomix® Sensor firmware update working?**

Make sure your Thermomix® Sensor is close to your smartphone and connected to the Cooking Center app. Once a connection is established, the app prompts you to update your sensor firmware if required. If no update prompt is available within the app you already have the latest version of the firmware installed on your device.

### **Updating your Thermomix® Sensor device**

*(See illustration next page.)*

If your Thermomix® Sensor is connected to the Cooking Center app and a firmware update is required, you will receive an update dialogue on the main screen of the app. Pressing the prompt will initiate the update dialogue which will guide you through the firmware update process.

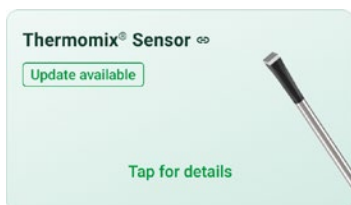

**Do not use the probe in a microwave or a pressure cooker.**

### Can I use Thermomix® Sensor in a pressure cooker?

Thermomix® Sensor does not support pressure cooking due to increased pressure which could result in moisture getting inside the probe thus damaging the circuitry.

Using Thermomix® Sensor in a pressure cooker would void the warranty although it may not necessarily break the device.

### Can I use Thermomix® Sensor in a microwave or a combination oven?

Unfortunately, you cannot use Thermomix® Sensor in a microwave as this would cause irreparable damage to the circuitry inside the probe itself. Besides, this is a fire hazard.

### Can I put my Thermomix® Sensor probe in the dishwasher?

Cleaning the probe by hand to extend the life is recommended over placing in the dishwasher.

### Should I be worried if my Thermomix® Sensor probe's ambient sensor doesn't match my cooker?

In most cases, built-in cooker thermometers measure the temperature in a different spot from where you put your food, like in the back of the oven or the lid of the grill. On top of this, there are usually hot and cold spots in the cooker, rather than having one consistent temperature throughout the whole chamber.

That's why it's important for Thermomix® Sensor's ambient sensor to read the temperature right at the black ceramic handle. It tells you the actual temperature your food is exposed to and helps to calculate a more accurate cook time.

### Should I be worried if my Thermomix® Sensor probe's internal sensor doesn't match another thermometer I'm using?

If you're using more than one thermometer to check your meat temperature, there's a couple of important things to keep in mind:

- While the meat is still cooking, there can be variations in temperature in different parts of the meat. This can happen because of differences in thickness, fat content, or proximity to bones.
- Even if you're trying to measure in exactly the same spot, most other thermometers have their sensors right in the tip, whereas ours is about ¾ inch from the pointed end.

The core function of Thermomix® Sensor is to give you perfect and consistent results every time. This is why all of our probes' internal sensors are calibrated to +/- 0.5 °C (1 °F) in the factory using certified tools, and then thoroughly tested.

### Why has the core temperature of my bread been reached, but the crust still does not look dark enough?

The outcome can vary depending on your oven settings and whether you are using a conventional or convection oven.

### Thermomix® Sensor said my meat or fish was ready, but it did not reach the doneness I aimed for, why?

Most issues with undercooking are due to probe placement.

The internal sensor of the probe is located about ¾ inch above the pointed tip.

It is important that this part of the probe is in the thickest part of the meat or fish.

Other issues when cooking manually might be related to the oven temperature which needs to be adjusted according to the type of meat you are cooking:

- For meats with a higher core temperature (e. g., soft pork belly at 200 °F), use a lower oven temperature (e. g., 300 °F conventional heating) to prevent drying or burning.
- For lower core temperatures (e. g., medium rare duck at 135 °F), use a higher oven temperature (e. g., 400 °F convection heating) to achieve a crispy skin without overcooking the core.
- For fall-apart tender meat (e. g., collagen-rich tough cuts like pulled pork), we recommend to cook at a low oven temperature, such as 200 °F. This longer cooking time at a lower temperature helps break down the collagen and results in a fork-tender texture.

### How do I register my Thermomix® Sensor products?

Your warranty is automatically active when you purchase our product from an authorized seller, so we don't have a product registration process.

If you have trouble with your Thermomix® Sensor, contact your local Customer Happiness Team.

The warranty for Thermomix® Sensor is 2 years.

Customer Happiness  
3255 E Thousand Oaks Blvd, Thousand Oaks, CA 91362

Hours: Monday-Friday 6:00am-6:00pm PT /  
Saturday 7:00am-3:30pm PT.

+1 888-867-9375

service@thermomix.us



## Food safety note

**Food safety is important to everyone. However, vulnerable population (children under 5, adults aged 60 and over, pregnant women and people with weakened immune systems) are at an increased risk for food poisoning and should always consume food cooked at safe core temperatures.**

**The default cooking points are not food safe core temperatures for all options and should therefore not be used when cooking for vulnerable people with increased food safety risk.**

### **Recipe photography and styling**

Ana Teixeira, Nantes, France, p. 24

Antonio Nascimento, Portugal, p. 20

Ben Dearnley, Australia, p. 33 (bottom left)

Craig Kinder, Australia, p. 25

Cristian Barnett, UK, p. 18, 19, 22 and 30

Dennis Savini, Switzerland, p. 23 (top right) and 28

Diana Moschitz, Vorwerk International, cover,  
p. 11, 14, 16 and 31

D3 Studio, Nantes, France, p. 21

Laurent Grivet (photo) and Gaëlle Goumand  
(stylist), Rennes, France, p. 29

Lukas Kirchgasser Fotografie, p. 26

Martin Gentschow, Dusseldorf, Germany, p. 32

Marie Sjoberg, Spain, p. 1–2

Rob White, Switzerland, p. 33 (top right)

Sonja Priller, Autriche, p. 23 (bottom left) and 27

Superhumans, Italie, p. 5, 6, 7, 9, 17, 35 36 and 41



The Bluetooth® word mark and logos are registered trademarks owned by Bluetooth SIG, Inc. Any use of these word marks and logos by Vorwerk Elektrowerke GmbH & Co. KG is under licence.

